

YHZS75 hauling mobile concrete mixing plant

YHZS75 hauling mobile concrete mixing plant (75m³/h) with running system is special construction concrete equipment designed independently by our company. It can be installed quickly on site. This mixing plant integrate mixer, batching system, running system, feeding system, weighing system, cement silo, screw conveyor and all the necessary equipment into together, installing on a transport chassis. We can deliver YHZSA series concrete plant to construction site in the hauling situation, then install quickly on site and get it to run without debugging. This equipment has the characteristic of high automatic, well mixing, high productivity, high flexibility, convenient operation, and good stability. By absorbing new technologies from overseas and domestic, the mobile concrete mixing plant has such characteristics as accurate weighing, homogeneous and efficient mixing, fast and clean delivery, convenient to move and operate, safe trailing, etc.



Main specification

- 1、 Capacity: 75m³/h(under standard working condition)
- 2、 Total power consumption: 88 KW
- 3、 Aggregate weighing precision: ±2%
- 4、 Cement weighing precision: ±1%
- 5、 Water weighing precision: ±1%
- 6、 Additive weighing precision: ±1%
- 7、 Cycling time: 72 seconds
- 8、 Control mode: PLC, can operate on full auto, semi-auto and manual modes

- 9、 Mixed material discharge height: 3800mm
- 10、 Working dimension: 18.1m×2.5m×8.227m
Transportation dimension: 18.6m×2.5m×4.353m
- 11、 total weight: approximated: 27tons

YHZS-75 MOBILE CONCRETE BATCHING PLANT

No.	Description		specification
1	Batching station	Aggregate hoppers	6m ³
		Mesh cover	100×100
		Air cylinder	QGB80×250
		Weighing hopper	4m ³
		Belt	B800×10×9460
		Electromotion drum	YD55108040
		Load sensor	CBLGM-S/2000
2	Belt conveyor	Troughed belt	B800×120×15000
		Electromotion drum	YD751258040
		Clean device	
3	Cement weighing system	Cement weighing hopper	0.7m ³
		Motor	11Kw
		Load sensor	CBLGM-S/300
		Butterfly valve	V1FS300SN
4	Water weighing system	Water weighing hopper	0.5m ³
		Water pump	65JDB35-8-0.75 Kw
		Submersible pump	3Kw
		Load sensor	CBLGM-S/500
5	Additive weighing system	Additive weighing bin	0.05m ³
		Butterfly valve	Φ65Butterfly valve
		Anti-corrosion pump	25CQ-15(1.1Kw)
		Load sensor	CBLGM-S/200
6	Mixing system	Mixer	JS1500
		Motor	Y180L-4 22Kw
		Gearbox	XWD9-17
		Air cylinder	QGB-ZZ125×250-L3
		Oil pump	SNB10-6J
7	Moving device	Tires	900-20
		Tires	825-12
8	Air supply	Air compressor	11Kw

	system	Filter/lubricator/regulator combine	QFLJM-L15
		Connector	
		Muffler	L15
		Air tube	
9	Control system	Industrial computer	Advantech
		PLC controller	Omron
		Console	
		Control cabinet	
		Electrical elements	Siemens/ LG
		Air conditioned control room	1P
		Cables	
10	Attached spare parts and tools	Relay	DC24V
		Relay	AC220V
		Monkey wrench	12 inch
		pliers	
		Screw drivers	8 inch
		Socket span, open-end span	8 pcs
		Grease lubricate gun	
		hammer	2 pound
		Oil gun	
		Sealing	For Mixer shaft
		Sealing	For mixer shaft
		Mixer paddle	For mixer
		Scaleboard	For mixer



Installation of YHZS75 mobile concrete mixing plant



Features of YHZS75 mobile concrete plant

Stability from national standard structural steel. | Efficiency from twin shaft mixer and short cycle time. | Reliability from famous brand components. | Quality from accurate weighing. | Mobility from movable trailing unit. | Easy to installation-uninstallation and operating. | Quick to produce from our own specially trained engineers. | Easy to move from compact structure. | Easy to maintain from the best service and parts support. | Easy to clean from mixer with high-pressure automatic cleaning system. | Less foundation costs (80% less than stationary concrete batching plants). | Less maintenance and operating costs. | Less transportation costs. | Minimized concrete transportation costs. | Fast return on investment.

General layout of YHZS75 mobile concrete plant

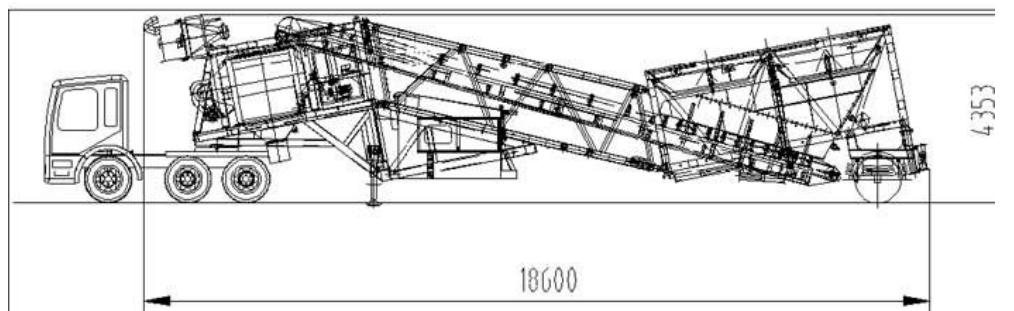

Please note of YHZS75 mobile concrete plant

1. The total power doesn't include the power of cement screw;
2. Non-standard design could be made according to clients' demand;
3. The above-mentioned data could be changed due to the designing improvement, please check the updated configuration when purchasing.

Application of YHZS75 mobile concrete plant

It can be applied to various construction sites like road surface, bridges, dams and airport, and also like architectural workings, concrete product plant and commercial concrete production.

Proper installation of a concrete batching plant is very important to the productivity of a concrete batching plant. Here are some installation steps to install a concrete batching plant

Installation steps of concrete mixig plant

- (1) Installation of finished material adhesive tape conveyor Expand finished material adhesive tape conveyor at its bends and then put frame on the base. Next, link legs with conveyor as well as the bracing piece and lifting lug. Thirdly, lift the front of conveyor and like legs and bracing piece well. Finally, fasten anchor bolt of legs well.
- (2) Installation of host and powder batching system Sling the rack of host and put it on the base. Then fasten its anchor bolt.
- (3) Installation of storage bin Sling storage bin and rise up legs. Link walking board, ladder and storage bin well.
- (4) Installation of aggregate dosing machine sling aggregate dosing machine to put it on the base. Link blank as well as heightening plate and blank. Next, expand aggregate conveyor. Link rack to make motorized pulley align cover hole center of concrete mixer. Finally, fasten anchor bolt.
- (5) Installation of cement silo Assemble all parts of cement silo well on the ground and then lift cement silo. Make support of it orient to power batching system and then fasten it. In the end, fasten anchor bolt.
- (6) Installation of screw conveyor Sling screw conveyor. Link spherical hinge of screw conveyor and discharging outlet of cement silo well to make discharging outlet align feeding inlet. Then link conveyor and lifting lug of cement silo by steel wire rope. Finally, fasten anchor bolt.
- (7) Lift water pump to a proper position and link output pipe well.
- (8) Put air compressor at one side of storage bin. Link exit of air compressor with entrance of gas control box. Lead exit of gas control box to air tube of cement silo.



After completion of the concrete mixing plant produce what issues need attention

concrete batching plant will be some unforeseen problems in production, it requires staff each position must be serious and responsible, to ensure that the production of some minor problems can be solved in time, but after the completion of production requires concrete batching station clean-up work, so as to ensure the efficient production next. So today we take a look at the concrete batching plant After production problems which need attention.

- 1, frozen season, was completed pump should be exhausted, additional coolant pump, water tank, additional agent tank, water, additives in the pipeline residual water, additives to prevent damage to Diesel concrete pump the pump and tubing, and start the pump additional coolant pump operate for 1-2 minutes.
- 2, clean the batching tank inside and outside wall fouling, the discharge mouth, concrete residue agitator shaft and discharge door, where rinse with water, if necessary, add a small amount of stone and water, stirring for several minutes release. Water for washing cars, and for the additional agent tank system.
- 3, the lubrication points are located out door shaft mixer, each hopper and weighing Doumen shaft, tape transport, machine roller, roller, roller bearings, drive chains, screw shaft, the lower bearing and host large gear, etc.
- 4, adjusted when checking blades, scraper, stirring arms and other necessary clearance for wear or replaced; vibrators without loosening bolts; check the electrical contact device; static and dynamic contact relay damage and burnout. These are concrete batching plant production work after the completion of the inspection and maintenance issues, although more complicated, but we must make these basic smooth production work can only be assured of.

concrete batching Plant

Packaging Details:

the host machine and other steel frame structure packed nakedly in the container; the electric items and installation components packed with strong and standard wooden packages. A wooden-box with the size of 60cm*60cm*60cm will be used for small items like bolt, nut, screw etc.

- 1. Container guarantee to not be damaged at the shipping.
- 2. Protective Packaging

- 3. Protective packaging according to the characteristics of the products. Packages after the water spray test, no water leakage.
- 4. Proof packaging Take the necessary measures moisture proof packaging goods.
- 5. Rust-proof packaging Products sealed with rust-proof material has a very good rust resistance, easy to remove







shipping:

by sea or by train; we have rich experience of shipping by sea or by train;



<http://haomei.biz/products/mobile-concrete-mixing-plants/250-mobile-concrete-mixing-plants.html>

About Haomei

Haomei machinery equipment co., ltd is located in the famous machinery capital of Zhengzhou, China. We are professional machinery products manufacturer—featuring a wide range of quality mobile concrete mixer, concrete batching plant, mobile concrete plant, concrete pump, truck pump with boom, truck mixer, etc. We adhere to the policy of "QUALITY FIRST AND INTEGRITY WINS" to cooperate with clients from all over the world. Seeking for long-term relationship and mutual benefit is our unstoppable goal.

Our company covers over 100 acres with workshop area of more than 50,000 square meters has 5 branches. We have over 1000 technical workers and 80 engineers equipped with advanced producing and inspecting machines with strict management. We focus greatly on our products quality and with such quality our products have been receiving admiration by clients from over 30 provinces in China and royal clients from overseas..

We categorize files for clients by computer so that we can view clients feedback and comments in time, tracking services and long-term warranty. In this way our clients will feel assured and comfortable in using our equipments..

Our main product: JZC/JZM250, 350, 500, 750 movable concrete mixers, PLD800, 1200, 1600, 1800, 2400, 3200, 4800 batchers, LSY series cement screws, HZS25, 35, 50, 60, 75, 90, 120, 150, 180, 240 concrete batching plant, YHZS25, 60, 75 mobile concrete batching plant, HBT series concrete pumps, truck-mounted boom pumps and truck mixers with different

capacities. We are confident to attract our clients from all over the world with our best quality concrete batching machines in China!.

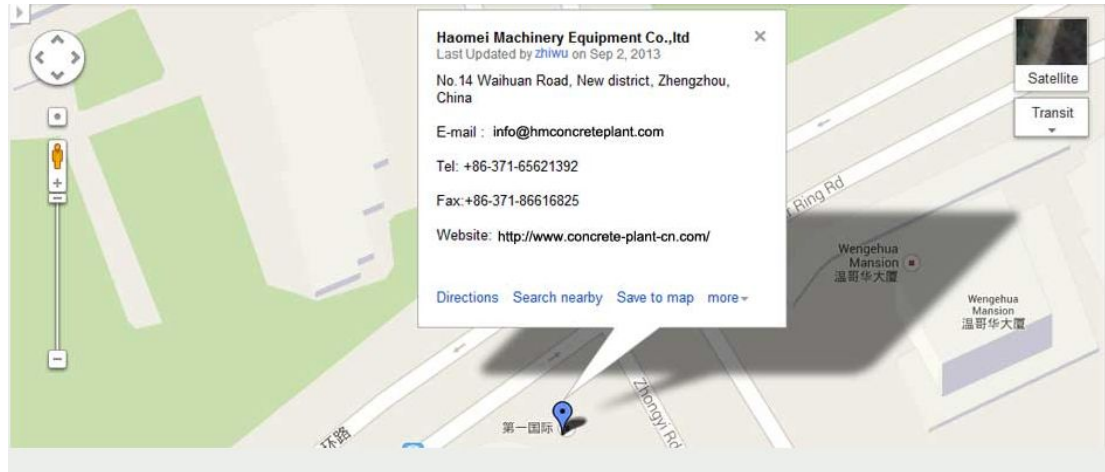

Haomei Machinery Equipment Co.,Ltd

Add : No.14 Shangwu Outer Ring Rd, New District, Zhengzhou, China.

E-mail info@hmconcreteplant.com

Tel: +86-371-65621392

Fax: +86-371-86616825

Website: [http:// haomei.biz](http://haomei.biz)

<http://haomei.biz/products/mobile-concrete-mixing-plants/253-mobile-concrete-mixing-plants.htm>

1